

Draft Guideline on procedures for Grant Certification

I. Legal background

- Circular No. 82/2007/TT-BTC dated 12/7/2007 by Ministry of Finance “Guideline on State financial management of foreign grants under the state budget receivables”

II. General information of the MHP pilot projects:

- The MHP pilot projects are ODA grant projects. These projects are entitled for exemption from different kinds of taxes such as equipment import tax, special consumption tax (if any), and value added tax (VAT).
- Project Management Agency: Ministry of Industry and Trade
- Project Owner/Grant Using Unit: Provincial People Committee / PMU
- Project implementation contract: the contract signed between Project Owner and Consortium of Contractors with contract price exclusive tax.

III. State financial management responsibilities of relevant parties related to grants of Sweden for the pilot projects (according to the circular 82/2007/TT-BTC)

1. Responsibilities of financial agencies:

1.1 Ministry of Finance: Playing the role of state financial management of foreign grants as the receivables of the central state budget (stipulation in point 1.1, item I, Part I of this Circular) the Ministry of Finance has the following main responsibilities:

a) Guiding implementation of financial management rules for foreign grant resource; Being responsible for controlling implementation of financial regulation to central and local agencies that are the management agencies of the programmes/projects with foreign grants to the State or Government of Socialist Republic of Vietnam.

b) *Implementing certification of grants and accounting them to the state budget for foreign grants belonged to the central state budget.*

1.2 Provincial Department of Finance: Implementing function of state financial management for foreign grant directly given to the locality, belonged to the local state budget (stipulation in point 1.2, item I, Part I of this Circular) and having the main responsibilities as follows:

a) Guiding and checking implementation of financial management rules for foreign grant resource directly provided to locality.

b) Implementing acknowledgement of grants and accounting them to the state budget for foreign grants directly provided to the local central state budget.

c) Coordinating with Ministry of Finance in accounting state budget for foreign grant resources belonged to the state budget receivables used as support for local budget.

2. Responsibilities of Project Management Agency and Project Owner/Grant Using Unit:

2.1 Project Management Agency:

a) Coordinating with financial agencies in directing, instructing and checking its belonging units in regard to strict implementation of regulations on financial management and use of foreign grants.

b) Preparation and aggregation of total estimation on grant receivables and expenditures, inspecting, approving and informing of approval on budgetary final report on grants to the units under it.

2.2. Project Owner/Grant Using Unit:

a) Responsible to the law on implementation of programs, projects with foreign grants in compliance with provisions and commitments in Treaties, Agreements, or Foreign Grant Project Documents.

b) Listing and getting certification of financial agencies in Grant certification form in accordance with guideline in Item II, Part II of this Circular.

c) Complying with the financial management regulations in accordance with this circular.

IV. Certification of grant according to the circular 82/2007/TT-BTC

1. Certification of grant (quotation from circular 82/2007/TT-BTC)

1. **Certification of grant** is the certification made by financial agencies (Ministry of Finance, Provincial Department of Finance) on the *Grant Certification Form* prepared by Project Owner/ Grant Using Unit.

2. **Responsibilities on grant certification** of Ministry of Finance and provincial Departments of Finance of cities and provinces as specified in Item VI, Part I of this Circular.

3. Purpose of grant certification:

3.1 Grant certification will help financial agencies to make reports on situation and data on receiving foreign grants, and will be one of legal documentation for accounting the state budget and appraising the final statement on use of grant submitted by Project Owner/Grant Using Unit to make sure that use of grant is in compliance with the Law on State Budget.

3.2 *The grant certification form is one of legal documents for:*

a) Customs office to implement exemption of import tax, special consumption tax (if any), and VAT for imported equipment, machines, materials, tools and goods financed by foreign grants; or for tax agencies to reimburse VAT for ODA grant goods and materials purchased within Vietnam.

b) Project Owner/Grant Using Unit shall prepare report on receiving and using grant in compliance with this circular.

4. **Format of Grant Certification Form** is available in the Annex 1 of this Circular, including:

4.1 Format C1-HD/XNVT: “Declaration form for certification of grant imported goods” (Annex 1a): is used in declaration for grant certification to imported equipment, machines, materials, tools and goods.

4.2 Format C2-HD/XNVT: “Declaration form for certification of grant domestic purchased goods, services” (Annex 1b) is used for declaration for grant certification to equipment, machines, materials, tools and goods purchased in Vietnam and financed by ODA grant (including service charges).

4.3 Format C3-HD/XNVT: “Declaration form for certification of grant in cash” (Annex 1c) is used for declaration of foreign grant in cash.

4.4 Notes for declaration of grants:

a) In case the foreign grant for the national or sectoral program, inter-sectoral program or inter-regional program: The Project Owner shall clearly declare in the declaration form for grant certification the name, address, code of the state budget using (pursuant to the Decision No. 172/2000/QD-BTC dated 1/11/2000 of Minister of Finance) and amount of grant allocated to each Grant Using Unit so that financial agencies at different levels can do state budget accounting.

b) In case the foreign grant is in form of goods, equipment and currency for implementation of basic construction project and after completion, the project will be transferred to Vietnam side in the form of “turnkey” (hereinafter referred as the grant for construction of the project): the Project Owner/Grant Using Unit also use the above mentioned formats C1, C2 and C3-HD/XNVT for declaring for grant certification but need to stick at the point of “Grant for construction of project”, and provide additional information on the construction project (name, site, anticipated time for construction and taking over the project) on the back page of the form. After project is completed and transferred from the Donor to Vietnam side, the Project Owner/Grant Using Unit shall aggregate all the above Grant Certifications to make a Summary of Grant Certifications for the construction project (pursuant to the formats in Annex 2 of this Circular). This Summary of Grant Certifications together with Commissioning report, project taking-over report are the legal documentation for Project Owner/Grant Using Unit to prepare the Final Financial Statement of the project which being sent to the competent authority for appraising and approving. The Summary of the Grant Certifications is also the base for financial agencies to account all expenses and receipts of the project into the state budget.

5. Grant Certification Form shall be made at least 6 original copies, of which:

5.1 Financial agency keeps 2 copies (1 for accounting stage budget and 1 for detaining at grant registration book);

5.2 Customs agency/tax agency, each keeps 1 copy for processing of tax and detaining in the Dossier of tax exemption/reimbursement;

5.3 The Project Management Agency keeps 1 copy for monitoring management and preparing report of foreign grant;

5.4 Project Owner/Grant Using Unit keeps 1 set for preparing reports on grant receiving, payment and liquidation of granted project, program.

In case granted goods are vehicles (vehicles, motorbikes...), the Project Owner/Grant Using Unit shall prepare 1 more copy for the purpose of vehicle registration later.

6. Subjects for preparation of Grant Certification Form:

The Grant Certification Form declared by Project Owner/Grant Using Unit is registered in Grant registration book of the authorised financial agency and certified by authorised body with signature.

7. Time for preparation of Grant Certification Form:

7.1 Format C1-HD/XNVT: “Format C1-HD/XNVT: “Declaration Form for Grant Certification to imported goods” shall be prepared right after Owner/Grant Using Unit received the evidence document of imported goods (Invoice; Bill of Lading; Airway Bill and/or other transportation vouchers, if any);

7.2 Format C2-HD/XNVT: “Declaration Form for Grant Certification to Grant domestic purchased goods, services” shall be prepared monthly at the same time when Owner/Grant Using Unit prepares detailed Summary for VAT reimbursement for the granted program, project;

7.3 Format C3-HD/XNVT: “Declaration Form for Grant Certification to grant in cash” shall be prepared right after receiving vouchers of money transfer from foreign country to Vietnam.

8. Necessary documents attached to the Grant Receipt Form:

8.1 For the first Grant Certification Form, Owner/Grant Using Unit shall provide to the financial agency the following documents:

- a) Set of legal documents of the granted program, project, including:
 - Project, program document and approvals of competent authorities;
 - International treaty, agreement or commitments on grant;
 - Financing plan, budget estimates or announcement on grant allocation (if these documents are not available in the approved program, project documents).

Besides, in case of non-governmental grant, Project Owner/Grant Using Unit shall coordinate with the functional agencies in order to provide additional information of permission and operation of the related non-governmental organizations.

b) Documents, vouchers proving granted goods, services or project such as vouchers of import, announcement of budget disbursement or voucher of money transfer from the donor, vouchers on purchase of goods and services in the country, purchase contracts, minutes of handing-taking over, final financial statement of the ODA grant construction project in the form of “turnkey project” and other related documents.

8.2 For governmental grants through one organization, unit under the Government, but Grant Using Unit is local organization, unit, in the first time of preparation of Grant Certification Form, a set of legal documents of granted program, project shall be made more copies (depending on quantities of local units using grant) for submitting to the Ministry of Finance. The Ministry of Finance will forward copies of legal documents to the related Provincial Department of Finance for coordinating in management and accounting into the state budget.

For next times of preparation of Grant Certification Form, Project Owner/Grant Using Unit shall provide specific documents as specified in Point 8.1 b).

8.3 Project Owner/Grant Using Unit shall list all mentioned documents in the Grant Certification Form and is responsible to the law on accuracy of provided data and contents.

9. Location for grant certification:

9.1 Ministry of Finance: at the Department of International Finance – Ministry of Finance in Hanoi, or the Department’s units in Ho Chi Minh city and Da Nang city which in-charge of management and receiving of international grant goods;

9.2 Provincial Department of Finance: Depending on the actual situation, each locality can establish ad-hoc team for management or entrusts task to a functional division of the Department of Finance for implementation.

10. Notes for preparing Grant Certification Form:

10.1 Price:

a) Format C1-HD/XNVT: “Declaration Form for Grant Certification to imported goods”: according to the actual prices in foreign currency as shown on the bills (FOB, CIF, C&F...).

b) Format C2-HD/XNVT: “Declaration Form for Grant Certification to grant domestic purchased goods, services”: according to the prices without tax as in the contract signed by and between Contractor/supplier and Project Owner.

10.2 The exchange rate for converting foreign currency into Vietnamese Dongs: According to the exchange rates which are monthly published by the Ministry of Finance at its website (<http://www.mof.gov.vn>).

10.3 In order to facilitate processing tax and accounting the state budget for grant resources, information of Project Owner/Grant Using Unit shall ensure the main requirements as follows:

a) Exact full name, contact address of Grant Using Unit, Project Owner, and Project Management Agency.

b) Codes of units using state budget of the Project Owner/Grant Using Unit; for units using grant which are enterprises or administrative units with receivables, the VAT code needs to be declared for VAT reimbursement purpose.

Procedure for Grant Certification

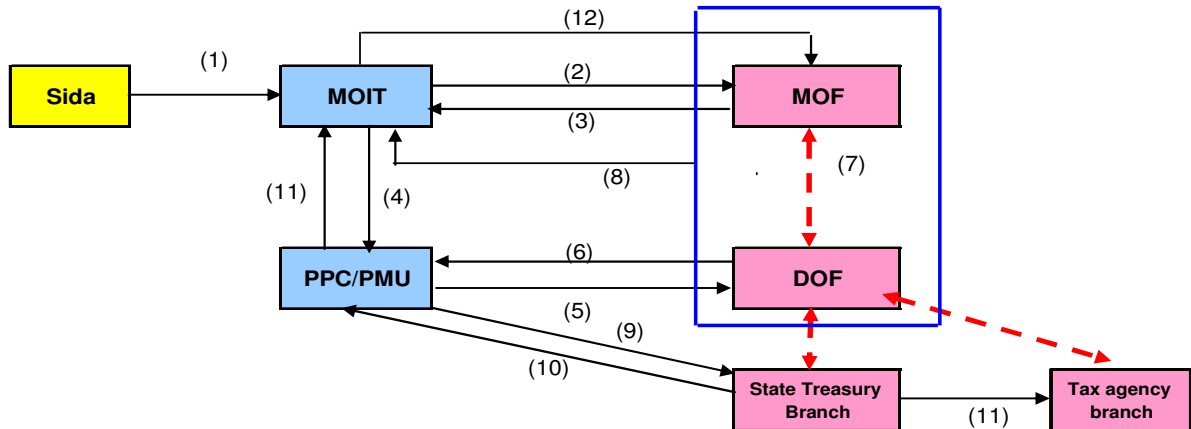

- (1) **Sida** transfers grant for 4 pilot projects
- (2) **Ministry of Industry and Trade (MOIT)** prepares declaration form for Grant Certification to the received grant in cash according to format C3-HD/XNVT promulgated along with circular 82/2007/TT-BTC attached with Dossier of Legal Documents of the Program and requests Ministry of Finance to certify grant (the form shall be made in 15 original copies, of which 2 copies for Ministry of Finance, 2 copies for tax agency/customs office, 1 copy for Ministry of Industry and Trade, 2 copies for two provincial People Committees, 2 copies for two PMUs, two copies for two Departments of Finance, two copies for two Provincial Branches of State Treasury).
- (3) **Ministry of Finance (MOF)** shall certify on the Grant Certification Form and send announcement of grant certification together with dossier of grant certification, including:
 - . Detailed list of Grant Using Units
 - . Copies of certified Grant Certification Form
- (4) **MOIT** sends notice of certification of grant together with copy of **Dossier of grant certification** and **set of legal documents** of the project to PMU and provincial branches of state treasury as base for monitoring and controlling expenditure.
- (5) **PMU requests for certification for grant imported goods and grant domestic purchased goods, services** :
 - . For imported goods: Upon receiving vouchers of imported goods provided by contractor, PMU shall prepare the Grant Certification Form (at least 6 original copies) according to format C1-HD/XNVT promulgated together with circular No. 82/2007/TT-BTC and requests for certification from Department of Finance.
 - . For goods, services purchased in Vietnam: monthly, PMU prepares the Grant Certification Form (at least 6 original copies) according to format C2-HD/XNVT promulgated together with circular No. 82/2007/TT-BTC and requests for certification from Department of Finance
- (6) **Department of Finance** certifies on the Grant Certification Form and sends certified Grant Certification Form to PMU. *The grant certification form is one of the legal documents for customs office to make exemption of import tax, special consumption tax (if any), and VAT for imported equipment, machines, materials, tools and goods; or for the tax agency to reimburse VAT for goods, services purchased in Vietnam by using foreign grant.*
- (7) Monthly, **Financial Agency** shall aggregate all the grant certification forms from Grant Using Units to prepare a Summary of grant certifications for grant imported goods and grant domestic purchased goods and services (according to the formats in the Annex 3 of Circular 82/2007/TT-BTC) for each Grant Using Unit at level 1 of state using units (unit directly receiving annual budget plan decided by Prime Minister or Chairman of provincial People Committee) and makes accounting into the state budget on this basis.
- (8) After making the accounting into the state budget, the **Financial Agency** shall send announcement to the Project Management Agency which is state budget using agency level I (MOIT), together with dossier of state budget accounting,
 - . Notification of Approval of budget estimation
 - . Summary of Grant Certification of each Project Owner/Grant Using Unit
 - . Copy of Grant Certification Form of Project Owner/unit using grant*(This dossier is the base for Project Management Agency to do procedure for delivery of grant to Project Owners)*
- (9) Monthly, PMU prepares "Summary of expenditures financed by the grant in cash" and sends it to the Provincial State Treasury Branch for certification of paid amount from the grant resource (using formats in Annex 4, Circular 82/2007/TT-BTC)
- (10) **Provincial State Treasury Branch (PSTB) sends certification on the Summary of expenditures financed by the grant in cash to PMU**
- (11) **PMU** sends the Summary of expenditures, which is certified by provincial Branch of State Treasury, to MOIT for reporting and Provincial Tax Agency Branch (PTAB) as base for reimbursement of VAT to the main contractor.
- (12) **MOIT** shall collect and send "Certified Summary of expenditures financed by the grant in cash" to MOF for MOF to do accounting into the state budget.

Ministry of Finance, Department of Finance, Provincial State Treasury Branch (PSTB), Provincial Tax Agency Branch (PTAB) shall coordinate in management of the state Budget.

Dossier of legal documents of the Program:

1. Notarized program document and Decision of approval No. 905/VPCP-QHQT dated 3/3/2003 by the Government
2. Copies of 2003-2006 Development Corporation Agreement certified by Ministry of Industry and Trade
3. Voucher of money transfer to the special account level I at the Service Bank (Bank for Agriculture and Rural Development)

For PMUs, when doing procedures for grant imported goods and grant domestically purchased goods and services at first time, apart from the above mentioned dossier, the following legal documents shall be added:

4. Decision approving the total investment cost by Ministry of Industry and Trade (the copy stamped and signed by competent body) (in the decision approving investment, is clearly stated that the capital resource for implementation of the pilot projects is ODA grant from Sweden).
5. Paper of Provincial People Committee entrusting task for management and implementation of the pilot project to PMU (copy signed and stamped by PMU).
6. Decision approving bidding results for implementation of the project (copy signed and stamped by PMU).
7. Contract signed between PMU and Consortium of Contractors (copy signed and stamped by PMU).
8. **Certification of PMU for contract with Consortium of Contractors: Signed contract with price exclusive tax (contract price without tax is..... VND). PMU is not allocated budget for paying VAT directly to the Consortium of Contractors.**